



LAUNDRY

DRY CLEAN PRESS HX-42



The Powerline HX-42 is the ideal combination dry clean press equipped with numerous features suited to fulfill your needs. Some features include the cast head & frame which allow for minimal noise during operation. Also, its high quality roll bearing design provides fluid operation.

STANDARD FEATURES

- Heavy duty cast frame
- Durable cast aluminum head
- Firm frame equipped with screw-less installation

Technical Data

Steam consumption	12.5 Kg/Hr
Steam pressure	6.9bar
Machine dimensions (LxWxH)	1200 mm x 1200 mm x 1420 mm (47.24" x 47.24" x 55.91")
Shipping dimensions (LxWxH)	1440 mm x 1540 mm x 1380 mm (56.69" x 60.63" x 54.33")
Net weight	428 Kg (943.58 lbs.)
Gross weight	531 Kg (1170.65 lbs.)

Detail & Dimensions

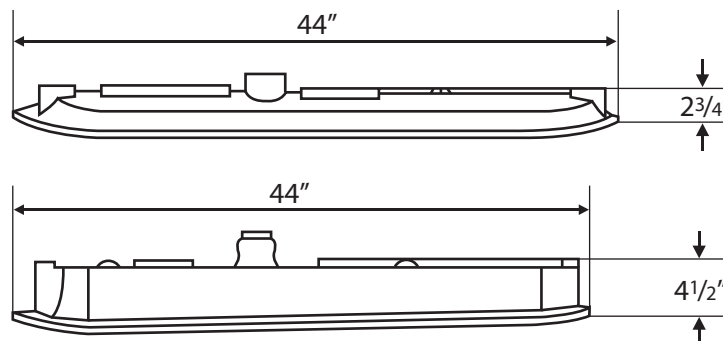

As continued product improvement is a policy of Powerline, specifications are subject to change without notice.



POWERLINE EQUIPMENT COMPANY

Pulaski Street, Norwalk, CT 06851 USA. Tel: 203-847 2357 Fax: 203-847 6480

www.powerlineequip.com