



LAUNDRY

TUMBLE DRYER PES-75



AVAILABLE OPTIONS

- T1 configuration: One way tilt: The dryer tilts forward to unload the linen
- T2 configuration: Two way tilt: The dryer tilts back to receive the linen from a conveyor and forward to unload it.
- FSC: Suction fan speed can be controlled (Not for gas dryers)
- Power control: The electric heated dryer can work at full or partial power
- The dryer is available in fully stainless steel. Frontal panels also available for order
- Available in gas, steam, or electric
- Coin operated: Coin box, prepaid key or central cash

STANDARD FEATURES

- Drum in stainless steel AISI 304
- External panels painted with epoxy powder
- Huge fluff filter, easily cleaned
- IM 7 microprocessor with 30 customizable programs
- Self-diagnostic with 11 available languages
- Drying parameters can be temporarily modified while the program is running
- Cooling cycle at the end of the program, additional cooling can be programmed at the beginning as well
- The heating cycle is composed of freely programmable steps
- The no wrinkle cycle ensures the finishing is easier, complimented by the universal drying of the reversing drum equipped with dry control. Great for delicate fabrics
- High Safety: The cycle stops when the door is opened at any time
- DSC: The drum speed can be programmed and modified standard for 1ph 230V models

TUMBLE DRYER PES-75

Technical Data

Washer capacity	75Kg
Drum dimensions (ØxP)	1202 mm x 1310 mm (890 mm load Ø)
Drum speed	40 RPM
Electric heating element	15 x 6.5 Kw
Steam heating power (Pressure)	149 Kw (8/15) 3/2" inlet 5/4" outlet
Gas heating power	115 Kw 4 burners 5/4 " connection
Exhaust	33 m ³ /min (300 mm drain Ø) (150 Pa pressure)
Noise	74 Db (A)
Machine dimensions (LxWxH)	1930 mm x 1360 mm x 2262 mm
Packing dimensions (LxWxH)	2050 mm x 1540 mm x 2411 mm
Net weight (Reversing)	1185 Kg (Gas) 1164 Kg (Electric) 1176 Kg (Steam)
Gross weight (Reversing)	1235 Kg (Gas) 1214 Kg (Electric) 1226 Kg (Steam)

Detail & Dimensions

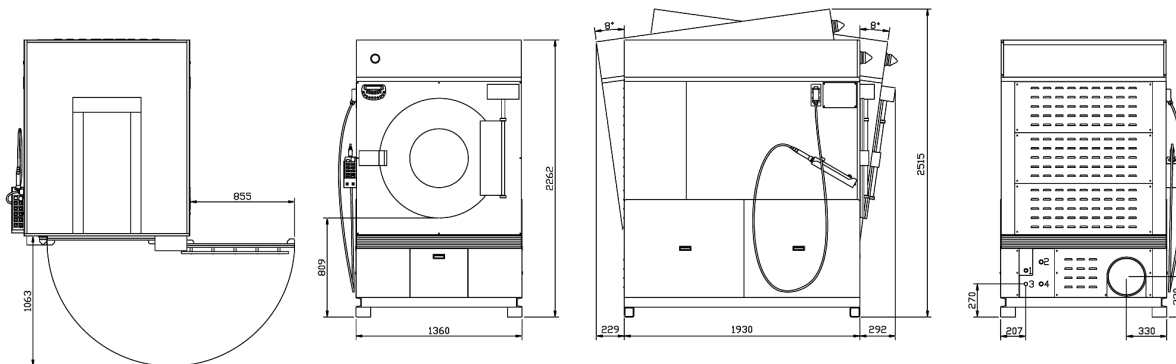

As continued product improvement is a policy of Powerline, specifications are subject to change without notice.



POWERLINE EQUIPMENT COMPANY

Pulaski Street, Norwalk, CT 06851 USA. Tel: 203-847 2357 Fax: 203-847 6480

www.powerlinelaundry.com